

REVISION RECORD			
REV.	DATE	DESCRIPTION	DCN
A	01-30-2013	INITIAL RELEASE	1816
B	02-28-2013	CHANGES PER DCN 1846	1846
C	11-19-2013	CHANGES PER DCN 2087	2087
D	12-20-2013	CHANGES PER DCN 2112	2112

ITEM	QTY	DESCRIPTION	MATERIAL
1	1	BODY	ASTM A351-CF8M
2	2	SEAT	TFM-1600
3	1	BALL	CF8M / 316 STAINLESS STEEL
4	1	ENDCAP	316 STAINLESS STEEL
5	1	GASKET	PTFE
6	1	STEM	316 STAINLESS STEEL
7	2	STEM WASHER	STAINLESS STEEL
8	3	PACKING	PTFE
9	1	STEM NUT	316 STAINLESS STEEL
10	1	BODY NUT	STAINLESS STEEL
11	1	HANDLE	GLASS FILLED NYLON

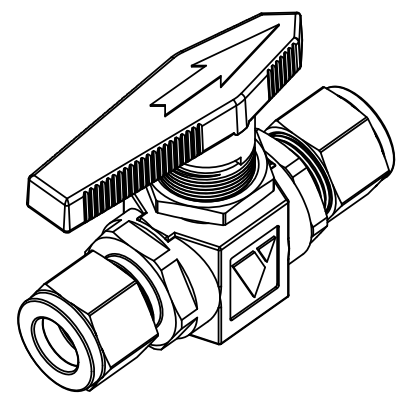

DIMENSIONS LISTED AS MILLIMETERS						
SIZE	"A"	"B"	"C"	"D"	"E"	"F"
1/4"	67.0	33.5	42.0	5.0	49.4	18.5
3/8"	77.2	38.6	45.0	7.8	59.5	24.5
1/2"	87.4	43.7	47.2	10.3	74.3	27.9
3/4"	98.0	49.0	48.2	12.0	74.3	27.9

1. DIMENSIONS ARE APPROXIMATE AND MAY VARY FROM VALVE TO VALVE.
2. DIMENSIONS ARE SUBJECT TO CHANGE AS PRODUCT IMPROVEMENTS MAY ALTER VALVE DESIGN.
3. OVERALL LENGTH DIMENSION IS CALCULATED ASSUMING COMPRESSION NUT IS FINGER TIGHT.

NOTES: UNLESS OTHERWISE SPECIFIED

CAD GENERATED DRAWING. DO NOT MANUALLY UPDATE		6080 LELAND ST. VENTURA, CA, 93003 (805) 658-0944 www.valex.com	
APPROVALS	DATE	<b>BALL VALVE, 2PC</b> STRAIGHT, COMPRESSION ENDS	
DRAWN	C. MAO 10-29-2012		
CHECKED	T. NEVINS 01-29-2013		
ENG.	C. MAO 01-28-2013		
C.A.	R. MULDRONG 01-28-2013	SIZE	DWG. NO.
MFG.	T. KELLENBERGER 01-28-2013	B	PDC-MBV-STR-CC
		SCALE: 1:1	REV. D
		SHEET 1 OF 1	