

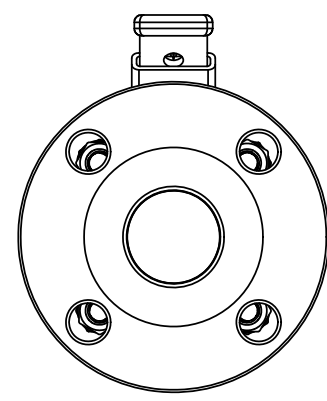

REVISION RECORD			
REV.	DATE	DESCRIPTION	DCN
A	02-20-2013	INITIAL RELEASE	1758
B	04-16-2013	CHANGES PER DCN 1896	1896
C	03-10-2014	CHANGES PER DCN 2103	2103
D	05-22-2018	CHANGES PER DCN 3976	3976

DIMENSIONS IN MILLIMETERS				
SIZE	"A"	"B"	"C"	"D"
NPS 3/4"	126.0	58.5	65	133
NPS 1"	139.5	63.5	74	159
NPS 1-1/2"	194.0	99.0	91	198
NPS 2"	216.5	114.5	99	198
NPS 3"	263.7	123.7	149	260

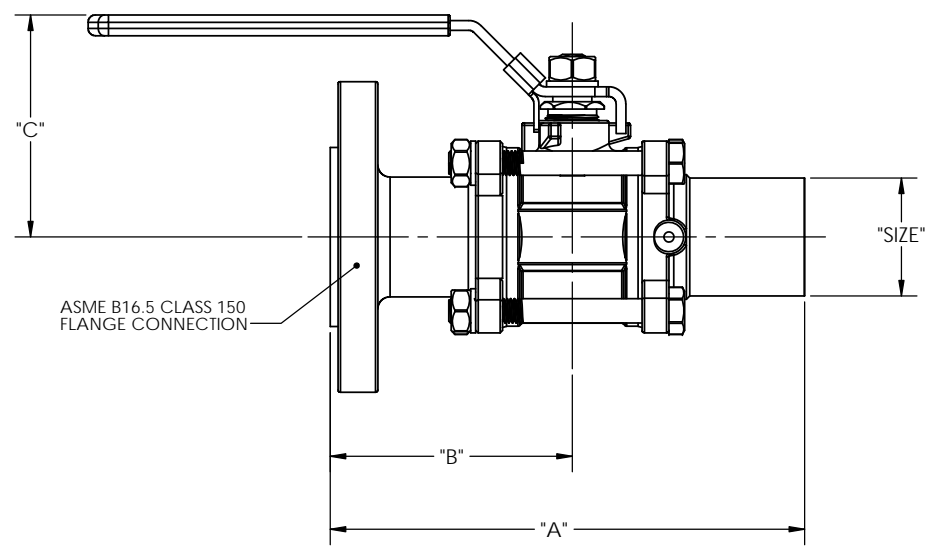
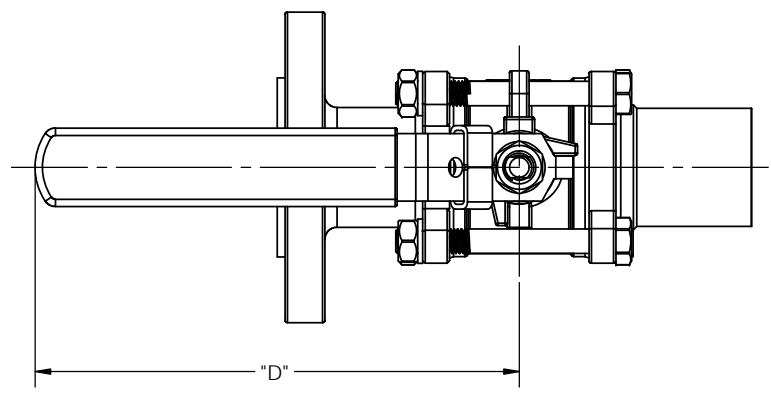

1. DIMENSIONS ARE APPROXIMATE AND MAY VARY FROM VALVE TO VALVE. REFERENCE VALEX SPECIFICATION SP-9236 FOR OVERALL LENGTH TOLERANCES.
2. DIMENSIONS ARE SUBJECT TO CHANGE AS PRODUCT IMPROVEMENTS MAY ALTER VALVE DESIGN.

NOTES: UNLESS OTHERWISE SPECIFIED

CAD GENERATED DRAWING. DO NOT MANUALLY UPDATE		 6080 LELAND ST. VENTURA, CA, 93003 (805) 658-0944 www.valex.com	
APPROVALS	DATE	<b>BALL VALVE, PCW          STRAIGHT, PIPE X FLANGE</b>	
DRAWN C. MAG	01-15-2013		
CHECKED T. NEVINS	02-14-2013		
ENG. C. MAG	02-14-2013		
C.A. R. MULDRON	02-14-2013	SIZE B	DWG. NO. PDC-PCW-STR-LF
MFG. T. KELLENBERGER	02-14-2013	SCALE: 1:2	REV. D
		SHEET 1 OF 1	