

REVISION RECORD			
REV.	DATE	DESCRIPTION	DCN
I	03-28-2012	CHANGES PER DCN 1547	1547
J	06-17-2019	CHANGES PER DCN 4390	4390

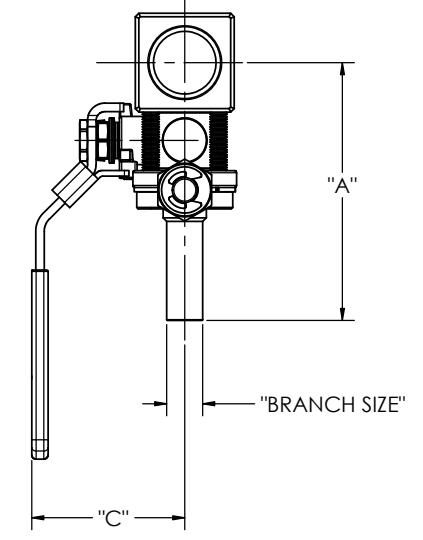

OPTIONAL BRANCH VALVE  
FACE-SEAL PURGE PORTS SHOWN.  
COMPRESSION FITTING PURGE  
PORTS ALSO AVAILABLE.

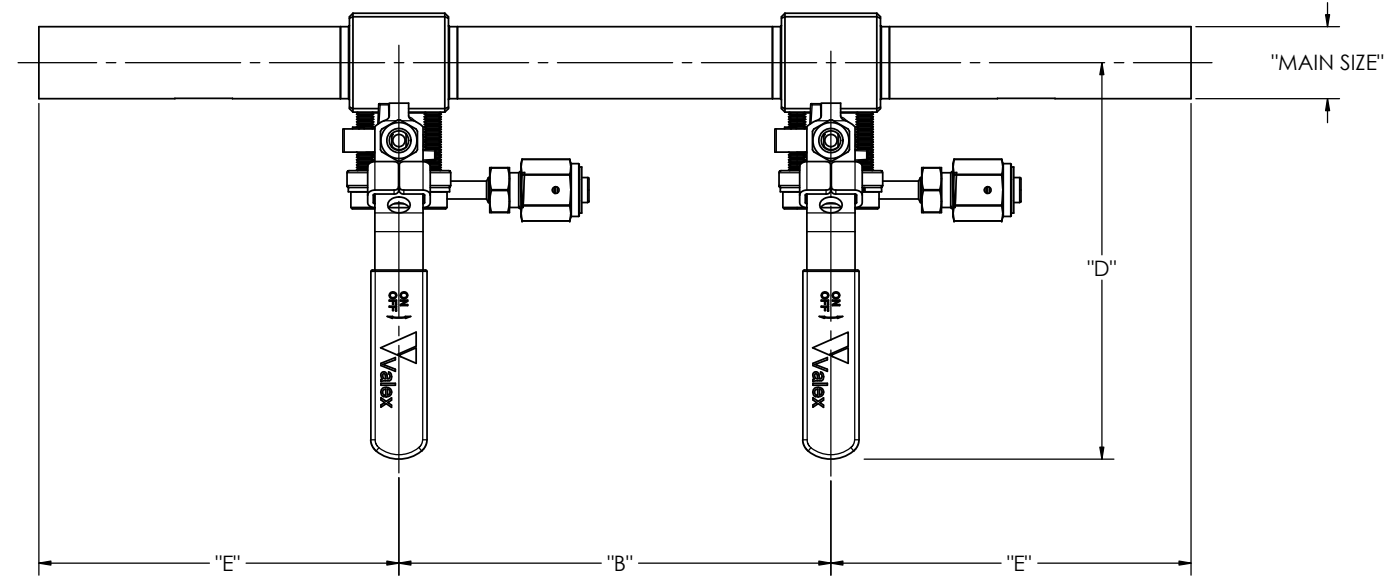
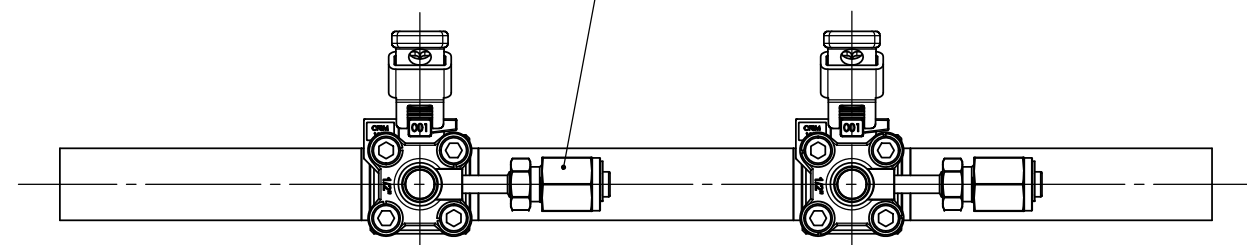

OPTIONAL END CAP SHOWN  
WELDED TO TUBE STUB

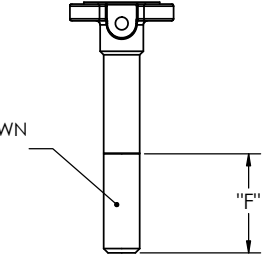

1. DIMENSIONS ARE APPROXIMATE AND MAY VARY FROM VALVE TO VALVE  
REFERENCE VALEX SPECIFICATION SP-9217 FOR OVERALL LENGTH TOLERANCES.
2. DIMENSIONS ARE SUBJECT TO CHANGE AS PRODUCT IMPROVEMENTS MAY ALTER VALVE DESIGN.
3. OVERALL LENGTH DIMENSION IS CALCULATED ASSUMING COMPRESSION NUT IS FINGER TIGHT.

NOTES: UNLESS OTHERWISE SPECIFIED

CAD GENERATED DRAWING DO NOT MANUALLY UPDATE		 6080 LELAND ST. VENTURA, CA 93003 (805) 658-0944 www.valex.com	
APPROVALS	DATE	<b>BALL VALVE, DSS CROSS, TUBE ENDS</b>	
DRAWN: C. MAD	01-24-2002		
CHECKED: C. MAD	02-20-2002		
ENG: C. MAD	02-20-2002		
QA: R. MULDONG	02-21-2002		
MRG: T. KELLNERBERGER	02-21-2002	SIZE: C DWG. NO.: PDC-DSS-MM SCALE: 0.75:1 REV: J SHEET 1 OF 2	

**DIMENSIONS IN INCHES**

SIZE		"A"	"B"	"C"	"D"	"E"	"F"
MAIN	BRANCH						
1/2"	1/4"	3.33	6.00	2.16	5.48	5.00	1.13
	3/8"	3.33	6.00	2.16	5.48	5.00	1.13
	1/2"	3.58	6.00	2.16	5.48	5.00	1.38
3/4"	1/4"	3.33	6.00	2.16	5.48	5.00	1.13
	3/8"	3.33	6.00	2.16	5.48	5.00	1.13
	1/2"	3.58	6.00	2.16	5.48	5.00	1.38
	3/4"	3.93	6.00	2.32	6.42	5.00	1.75
1"	1/4"	3.33	6.00	2.16	5.48	5.00	1.13
	3/8"	3.33	6.00	2.16	5.48	5.00	1.13
	1/2"	3.58	6.00	2.16	5.48	5.00	1.38
	3/4"	3.93	6.00	2.32	6.42	5.00	1.75
	1"	5.06	7.00	2.92	7.96	6.50	1.75
1-1/2"	1/4"	4.82	6.00	2.16	6.97	6.00	1.13
	3/8"	4.82	6.00	2.16	6.97	6.00	1.13
	1/2"	5.07	6.00	2.16	6.97	6.00	1.38
	3/4"	5.22	6.00	2.32	7.70	6.00	1.75
	1"	5.34	7.00	2.92	8.24	6.50	1.75
2"	1/4"	5.10	6.00	2.16	7.25	6.00	1.13
	3/8"	5.10	6.00	2.16	7.25	6.00	1.13
	1/2"	5.35	6.00	2.16	7.25	6.00	1.38
	3/4"	5.48	6.00	2.32	7.99	6.00	1.75
	1"	5.63	7.00	2.92	8.53	6.50	1.75
	1-1/2"	6.88	9.00	3.76	11.10	7.50	2.00
3"	1/4"	5.57	6.00	2.16	7.72	6.00	1.13
	3/8"	5.57	6.00	2.16	7.72	6.00	1.13
	1/2"	5.82	6.00	2.16	7.72	6.00	1.38
	3/4"	6.00	6.00	2.32	8.49	6.00	1.75
	1"	6.13	7.00	2.92	9.03	6.50	1.75
	1-1/2"	7.40	9.00	3.76	11.62	7.50	2.00
4"	1/4"	6.07	6.00	2.16	8.22	6.00	1.13
	3/8"	6.07	6.00	2.16	8.22	6.00	1.13
	1/2"	6.32	6.00	2.16	8.22	6.00	1.38
	3/4"	6.50	6.00	2.32	8.99	6.00	1.75
	1"	6.63	7.00	2.92	9.53	6.50	1.75
	1-1/2"	7.97	9.00	3.76	12.19	7.50	2.00

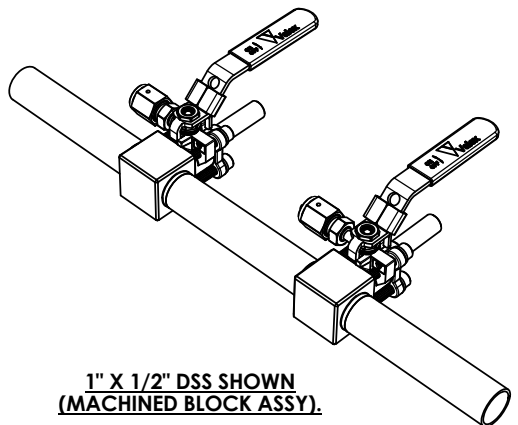

**1" X 1/2" DSS SHOWN  
(MACHINED BLOCK ASSY).**

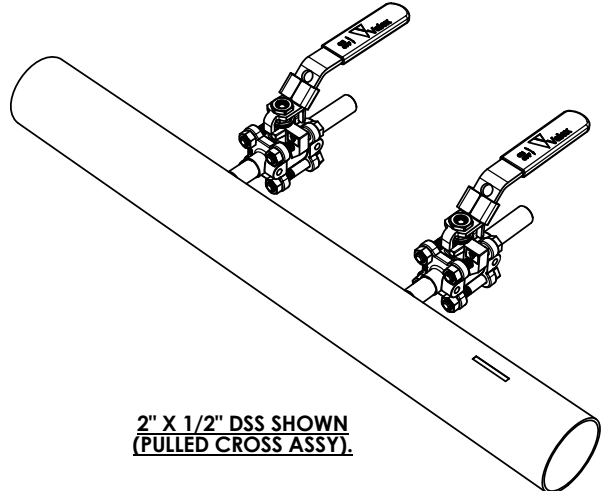

**2" X 1/2" DSS SHOWN  
(PULLED CROSS ASSY).**

		6080 LELAND ST. VENTURA, CA 93003 (805) 658-0944 www.valex.com	
		<b>BALL VALVE, DSS CROSS, TUBE ENDS</b>	
SIZE	DWG. NO.	REV.	
C	PDC-DSS-MM	J	
SCALE: 0.64:1		SHEET 2 OF 2	