

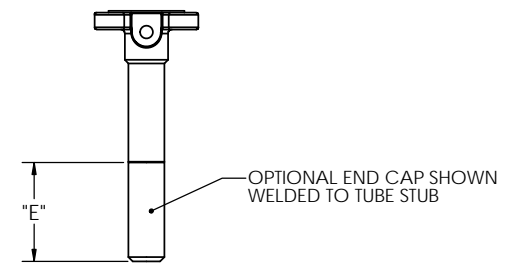

REVISION RECORD			
REV.	DATE	DESCRIPTION	DCN
F	05-06-2010	REVISE DIMENSIONS	1299
G	10-18-2010	ADD CONFIGURATIONS	1336
H	01-06-2011	REVISE DIMENSIONS	1358
I	03-28-2012	CHANGES PER DCN 1567	1567
J	08-26-2013	CHANGES PER DCN 2037	2037

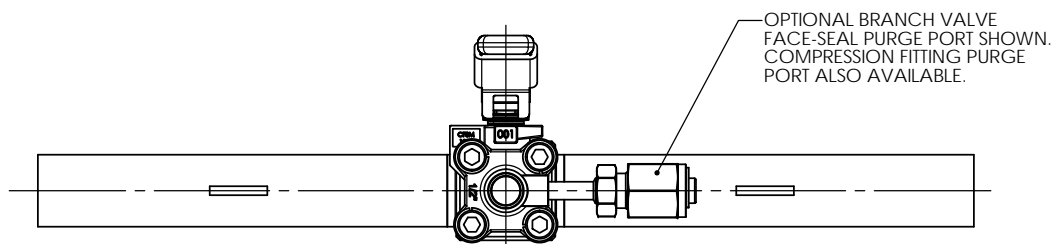
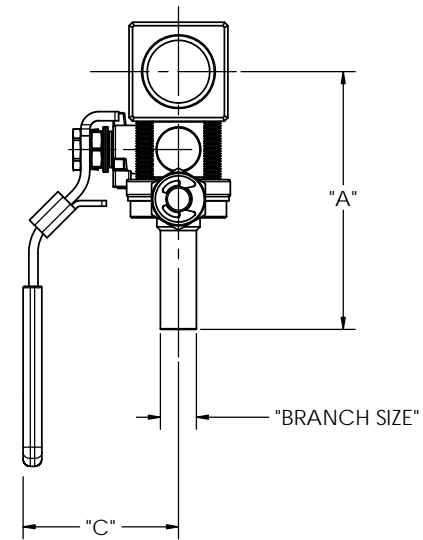
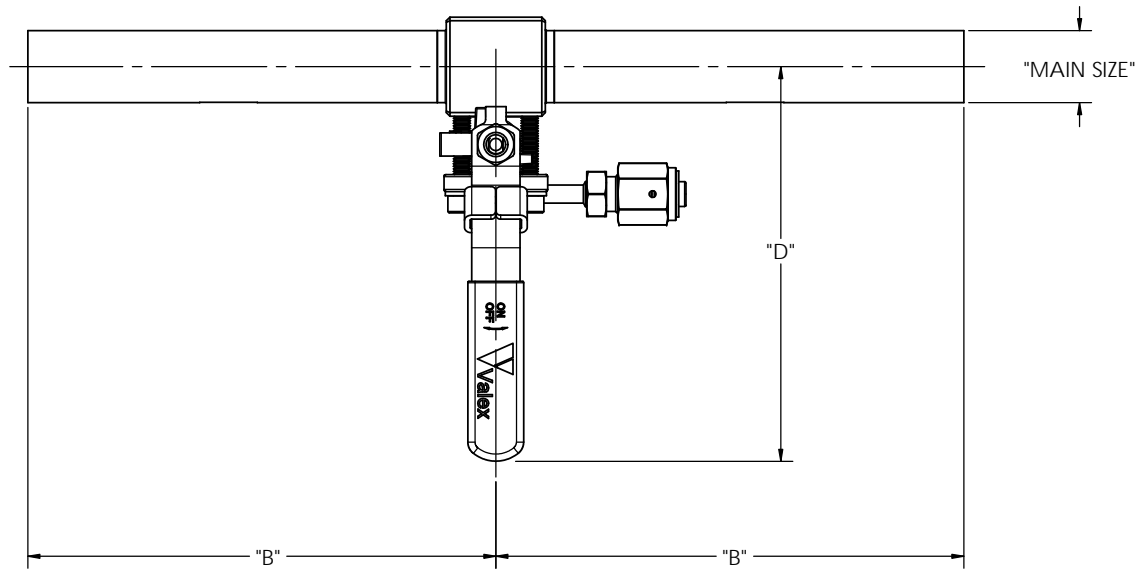

1. DIMENSIONS ARE APPROXIMATE AND MAY VARY FROM VALVE TO VALVE. REFERENCE VALEX SPECIFICATION SP-9217 FOR OVERALL LENGTH TOLERANCES.
2. DIMENSIONS ARE SUBJECT TO CHANGE AS PRODUCT IMPROVEMENTS MAY ALTER VALVE DESIGN.

NOTES: UNLESS OTHERWISE SPECIFIED

CAD GENERATED DRAWING. DO NOT MANUALLY UPDATE.		 6080 LELAND ST VENTURA, CA 93003 (805) 658-0944 www.valex.com	
APPROVALS	DATE		
DRAWN: C. MAG	01-24-2002	<b>BALL VALVE, SHC          CROSS, TUBE ENDS</b>	
CHECKED: C. MAG	02-20-2002		
ENG: C. MAG	02-20-2002		
D.A. R. MULDONG	02-21-2002		
MFG: T. KELLERBERGER	02-22-2002	Dwg. No: PDC-SHC-MM Scale: 0.75:1	Rev: J

**DIMENSIONS IN INCHES**

SIZE		"A"	"B"	"C"	"D"	"E"
MAIN	BRANCH					
1/2"	1/4"	3.33	5.50	2.16	5.48	1.13
	3/8"	3.33	5.50	2.16	5.48	1.13
	1/2"	3.58	5.50	2.16	5.48	1.38
3/4"	1/4"	3.33	6.50	2.16	5.48	1.13
	3/8"	3.33	6.50	2.16	5.48	1.13
	1/2"	3.58	6.50	2.16	5.48	1.38
	3/4"	3.93	6.50	2.32	6.42	1.75
1"	1/4"	3.33	6.50	2.16	5.48	1.13
	3/8"	3.33	6.50	2.16	5.48	1.13
	1/2"	3.58	6.50	2.16	5.48	1.38
	3/4"	3.93	6.50	2.32	6.42	1.75
	1"	5.06	6.50	2.92	7.96	1.75
1-1/2"	1/4"	4.82	6.50	2.16	6.97	1.13
	3/8"	4.82	6.50	2.16	6.97	1.13
	1/2"	5.07	6.50	2.16	6.97	1.38
	3/4"	5.22	6.50	2.32	7.70	1.75
	1"	5.34	6.50	2.92	8.24	1.75
	1-1/2"	6.59	6.50	3.76	10.81	2.00
2"	1/4"	5.10	6.50	2.16	7.25	1.13
	3/8"	5.10	6.50	2.16	7.25	1.13
	1/2"	5.35	6.50	2.16	7.25	1.38
	3/4"	5.48	6.50	2.32	7.99	1.75
	1"	5.63	6.50	2.92	8.53	1.75
	1-1/2"	6.88	6.50	3.76	11.10	2.00
	2"	7.63	6.50	4.12	11.35	2.00
3"	1/4"	5.57	8.50	2.16	7.72	1.13
	3/8"	5.57	8.50	2.16	7.72	1.13
	1/2"	5.82	8.50	2.16	7.72	1.38
	3/4"	6.00	8.50	2.32	8.49	1.75
	1"	6.13	8.50	2.92	9.03	1.75
	1-1/2"	7.40	8.50	3.76	11.62	2.00
	2"	8.15	8.50	4.12	11.87	2.00
	2-1/2"	9.78	8.50	5.68	17.11	2.00
4"	1/4"	6.12	8.50	2.16	8.27	1.13
	3/8"	6.12	8.50	2.16	8.27	1.13
	1/2"	6.37	8.50	2.16	8.27	1.38
	3/4"	6.50	8.50	2.32	8.99	1.75
	1"	6.63	8.50	2.92	9.53	1.75
	1-1/2"	7.97	8.50	3.76	12.19	2.00
	2"	8.70	8.50	4.12	12.44	2.00
	2-1/2"	10.38	8.50	5.68	17.71	2.00
	3"	11.41	8.50	6.03	18.08	2.00
	4"	14.08	8.50	7.04	23.34	2.50
6"	1/4"	6.89	8.50	2.16	9.04	1.13
	3/8"	6.89	8.50	2.16	9.04	1.13
	1/2"	7.14	8.50	2.16	9.04	1.38
	3/4"	7.58	8.50	2.32	10.07	1.75
	1"	7.71	8.50	2.92	10.61	1.75
	1-1/2"	9.00	8.50	3.76	13.22	2.00
	2"	9.75	8.50	4.12	13.49	2.00
	2-1/2"	11.38	8.50	5.68	18.71	2.00
	3"	12.46	8.50	6.03	19.13	2.00
	4"	14.08	8.50	7.04	23.34	2.50

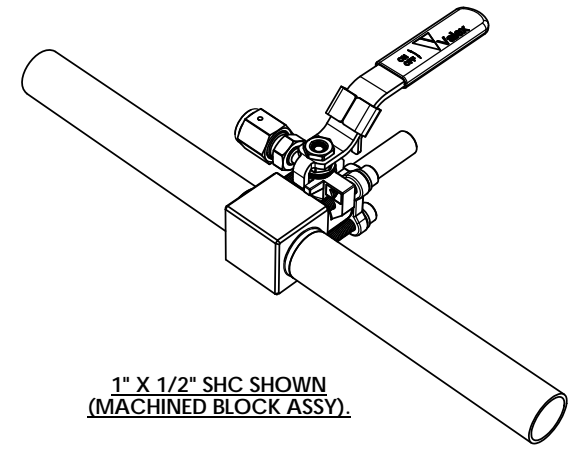

**1" X 1/2" SHC SHOWN  
(MACHINED BLOCK ASSY).**

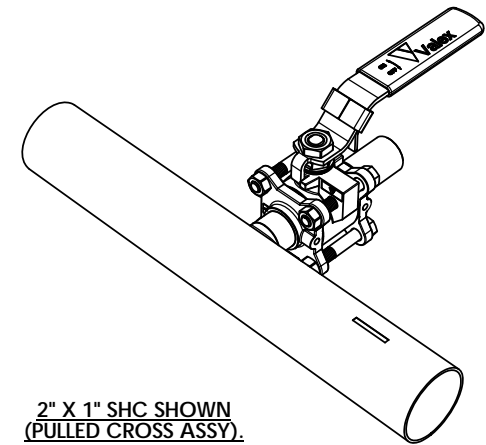

**2" X 1" SHC SHOWN  
(PULLED CROSS ASSY).**

		6080 LELAND ST VENTURA, CA 93003 (805) 658-0944 www.valex.com	
		BALL VALVE, SHC CROSS, TUBE ENDS	
SIZE C	DWG. NO. PDC-SHC-MM	REV. J	SCALE: 0:1 SHEET 2 OF 2