

REVISION RECORD			
REV.	DATE	DESCRIPTION	DCN
PRIOR APPROVALS ON FILE			
F	06-30-2009	CHANGES PER DCN 1221	1221
G	05-06-2010	REVISE DIMENSIONS	1299
H	09-29-2022	CHANGES PER DCN 5762	5762

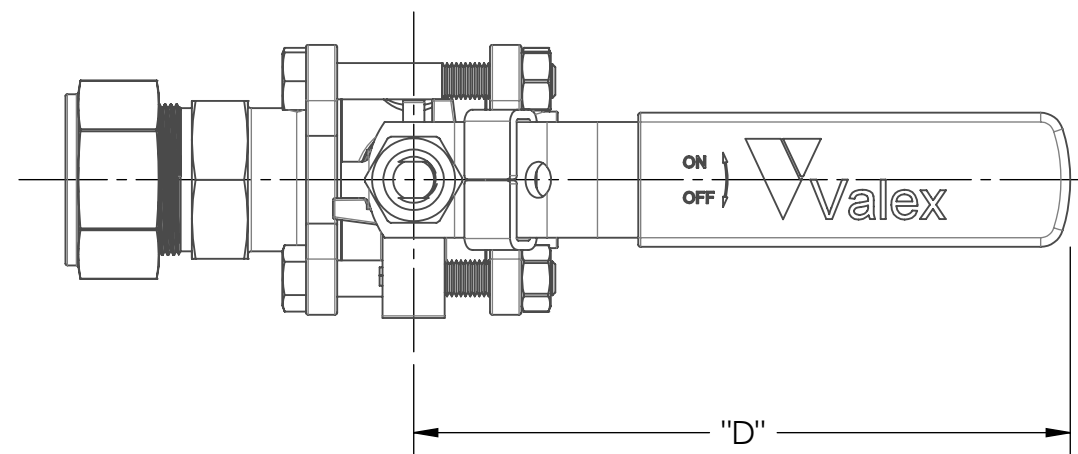

DIMENSIONS IN INCHES				
SIZE	"A"	"B"	"C"	"D"
1/4"	4.09	2.25	2.16	4.40
3/8"	4.18	2.25	2.16	4.40
1/2"	4.56	2.50	2.16	4.40
3/4"	5.01	2.63	2.32	5.11
1"	5.77	2.75	2.92	5.65
1-1/2"	7.80	3.50	3.76	7.72

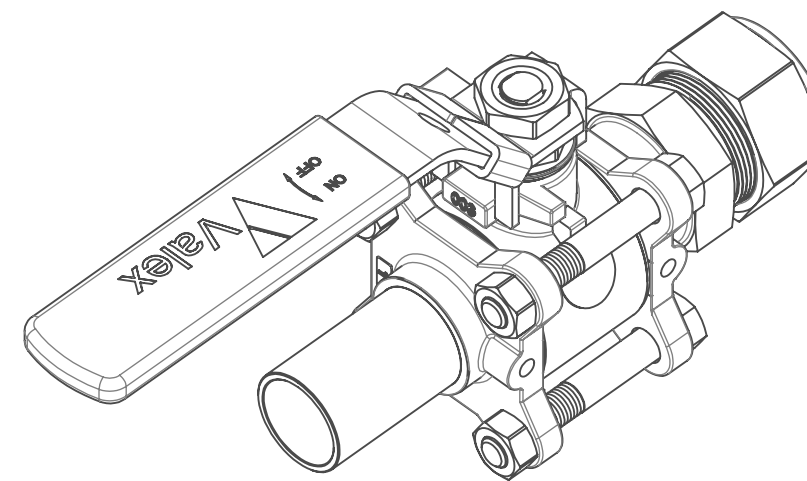
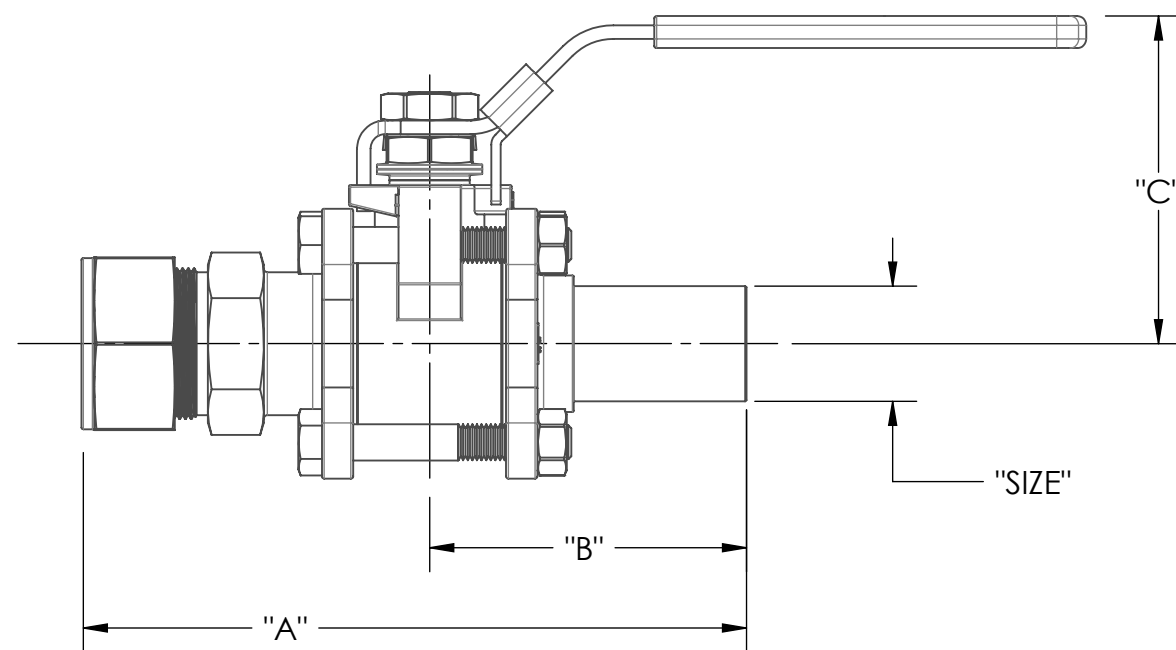

STANDARD FINISH OPTION SHOWN

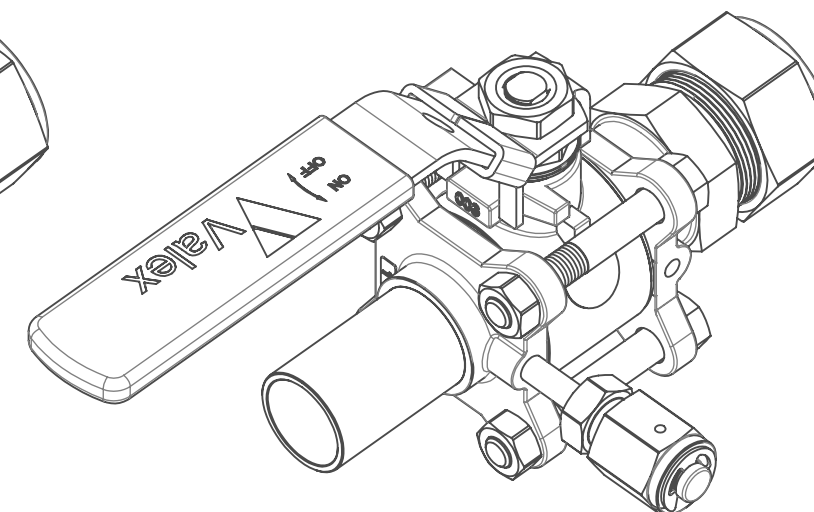

STANDARD FINISH OPTION SHOWN WITH OPTIONAL FACE-SEAL PURGE PORT (COMPRESSION PURGE ALSO AVAILABLE)

1. DIMENSIONS ARE APPROXIMATE AND MAY VARY FROM VALVE TO VALVE. REFERENCE VALEX SPECIFICATION SP-9217 FOR OVERALL LENGTH TOLERANCES.
2. IF PURGE PORT OPTION IS SELECTED, 1/4" PURGE WILL BE USED.
3. DIMENSIONS ARE SUBJECT TO CHANGE AS PRODUCT IMPROVEMENTS MAY ALTER VALVE DESIGN.
4. OVERALL LENGTH DIMENSION IS CALCULATED ASSUMING COMPRESSION NUT IS FINGER TIGHT.

NOTES: UNLESS OTHERWISE SPECIFIED

CAD GENERATED DRAWING. DO NOT MANUALLY UPDATE		 6080 LELAND ST. VENTURA, CA. 93003 (805) 658-0944 <a href="http://www.valex.com">www.valex.com</a>	
APPROVALS	DATE	<b>BALL VALVE, STR</b> STRAIGHT, COMP-IN, TS-OUT	
DRAWN	C. MAO 06-26-2001		
CHECKED	A. MAGANA 08-03-2001		
ENG.	R. KOTTLER 08-03-2001		
Q.A.	R. MULDONG 08-03-2001		
MFG.	T. KELLENBERGER 08-03-2001	SIZE B DWG. NO. PDC-STR-CM SCALE: 1:1.66667 SHEET 1 OF 1	