

THE INFORMATION CONTAINED IN THIS DRAWING IS THE SOLE PROPERTY OF VALEX CORPORATION. ANY REPRODUCTION IN PART OR WHOLE WITHOUT THE WRITTEN PERMISSION OF VALEX CORPORATION IS PROHIBITED.

REVISION RECORD			
REV.	DATE	DESCRIPTION	DCN
A	11-07-2008	INITIAL RELEASE	N/A
B	05-20-2009	CHANGES PER DCN 1198	1198
C	07-01-2009	CHANGES PER DCN 1221	1221
D	06-25-2010	CHANGES PER DCN 1307	1307

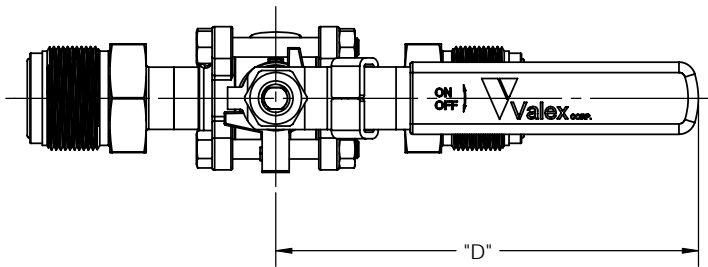

DIMENSIONS IN INCHES				
SIZE	"A"	"B"	"C"	"D"
1/4"	4.75	2.38	2.16	4.40
1/2"	5.00	2.50	2.16	4.40
3/4"	6.00	3.00	2.32	5.11
1"	6.75	3.38	2.92	5.65

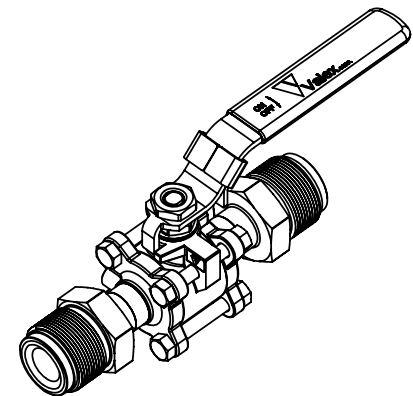
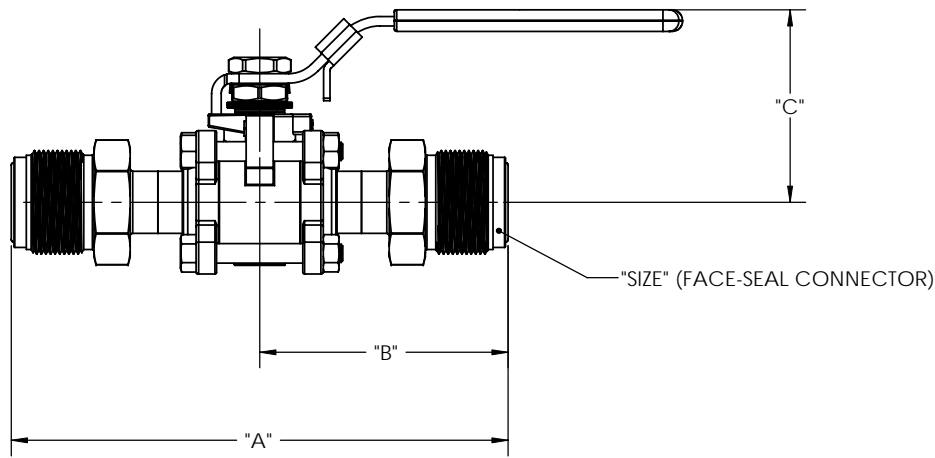

1. DIMENSIONS ARE APPROXIMATE AND MAY VARY FROM VALVE TO VALVE. REFERENCE VALEX SPECIFICATION SP-9217 FOR OVERALL LENGTH TOLERANCES.
2. IF PURGE PORT OPTION IS SELECTED (NOT SHOWN), 1/4" PURGE WILL BE USED.
3. DIMENSIONS ARE SUBJECT TO CHANGE AS PRODUCT IMPROVEMENTS MAY ALTER VALVE DESIGN.

NOTES: UNLESS OTHERWISE SPECIFIED

UNLESS OTHERWISE SPECIFIED DIMENSIONS ARE IN INCHES TOLERANCES ARE:		CAD GENERATED DRAWING. DO NOT MANUALLY UPDATE		 6080 LELAND ST. VENTURA, CA, 93003 (805) 658-0944 www.valex.com	
DECIMALS .XX ± .010 .XXX ± .005	ANGLES ± 1°	APPROVALS	DATE	BALL VALVE, STR STRAIGHT, FACE-SEAL ENDS	
BREAK ALL SHARP EDGES: N/A		DRAWN	11-07-2008		
MATERIAL SEE SP-9217		CHECKED	11-07-2008		
DO NOT SCALE DRAWING		ENG.	11-07-2008		
		C.A. R. MULDRONG	11-07-2008	SIZE B	DWG. NO. PDC-STR-FF
		MFG. T. NEVINS	11-07-2008	SCALE: 2:3	REV. D